

SEAFLOOR ACOUSTIC LOGGER UNIT: PRELIMINARY NOTES ABOUT A NEW TOOL FOR REMOTE UNDERWATER BIOACOUSTIC STUDIES

G. PAOLO SANINO^(1,2)

⁽¹⁾Centre for Marine Mammals Research - LEVIATHAN, Postal code 7640392 Santiago, Chile; research@leviathanchile.org

⁽²⁾National Museum of Natural History - MNHN, Casilla 787, Santiago, Chile.

ABSTRACT

Since their beginning in 1999, local cetacean passive hydroacoustic studies have increased in Chile, but have been limited to the traditional technique of deploying hydrophones from boats. Some of the main problems of this technique are reviewed, based on a personal experience. Here are discussed the results of the first tests of a self-made remote autonomous underwater sound recorder following specific needs that may be shared by other colleagues, but have not been fully addressed by other contemporaneous projects. The Seafloor Acoustic Logger is composed of two parts, a physical unit (SALu) to be installed on the seabed and a Java-based software interface (SALi) that allows for the recording schemes of SALu to be graphically setup from any personal computer, netbook or even smartphone that has an available USB port, in the lab or the field.

Recording schemes include: *Continuous*, automatically creating successive sound files of 1.9 GB; user defined *Periods*; up to 18 *Timers* that can be set up by date, time and duration; and *Trigger*, the innovation for a microcontroller-driven device of a signal-based recording mode that provides SALu with real-time analysis capabilities to decide whether or not to record incoming sound, by comparing peaks longer than 30 ms with a threshold preset by the user. *Trigger* is proposed as a feature to increase the efficiency of signal analysis in the lab, as it produces sound files composed primarily of the sought data as opposed to time-based events that may collect mostly environment background sound.

Based on a modified Microtrack II (M-Audio) digital sound recorder connected to a SQ26-8 hydrophone and controlled by a custom made printed circuit board, SALu was designed to collect underwater bioacoustic data in the form of digital sound files up to 24 bits of depth and 96 kHz of sample rate, and from <0.020 to 50 kHz, during a period depending on the preset recording mode. The endurance of recording can range between 14 and 86 days and nights, without the presence of the researcher nor his/her boat close to the sensor. By eliminating the behavioral reactions of animals studied to the presence of a boat and noise usually transferred to the sensor due to sea surface motion, SALu is presented as a valid complement to traditional hydroacoustic techniques, collecting data in remote locations or even when ports are closed due to weather conditions. SALu is recommended to support opportunistic and systematic behavioral and ecological bioacoustic studies, as well as assessments on cetacean interactions with fishing and aquaculture human activities. With simple modifications, SALu can also support inland bioacoustic studies on herpetology, mammalogy and ornithology, among others possible fields.

Key Words: Bioacoustics, Remote Recorders, Hydroacoustics, Sound Signal, Cetacean Vocalizations.

RESUMEN

Unidad de registro acústico autónomo de fondo de mar: notas preliminares sobre una nueva herramienta para estudios de bioacústica submarina. Desde sus inicios en 1999, los estudios locales de cetáceos mediante acústica pasiva submarina, se han incrementado pero siempre limitados a la técnica tradicional de desplegar hidrófonos desde embarcaciones. Algunos de los principales problemas de la técnica son revisados en base a una experiencia personal. Se discuten aquí, los resultados de las primeras pruebas de un nuevo registrador autónomo de sonido submarino diseñado para satisfacer requerimientos específicos que puedan ser compartidos por otros colegas y que no han sido abordados completamente por proyectos contemporáneos.

El *Seafloor Acoustic Logger* está compuesto por dos elementos, una unidad física (SALu) para ser instalada en el lecho del mar y una utilidad informática (SALi) escrita en lenguaje Java, que opera como una interfaz gráfica para configurar los esquemas de registro de SALu en terreno o en laboratorio, instalada en cualquier computador personal, netbook o incluso teléfonos inteligentes equipados con puertos USB.

Los esquemas de registro incluyen: *Continuo*, creando automáticamente archivos de sonido sucesivos de 1.9 GB; por *Periodos* definidos por el usuario; configurando hasta 18 *Temporizadores* por fecha, hora y duración; y *Trigger*, un innovador modo de registro para un equipo dirigido por un microcontrolador, basado en las propiedades de la señal en vez de sólo por tiempo, que le confiere a SALu la capacidad de análisis en tiempo real para decidir o no registrar el sonido entrante, mediante la comparación entre picos de más de 30 ms con un umbral previamente definido por el usuario. Dado que tiende a producir archivos principalmente con datos, en vez de eventos en base a tiempo que pueden registrar mayoritariamente sonidos ambientales de fondo, el modo de registro *Trigger* es propuesto como una utilidad para incrementar la eficiencia de la etapa del análisis en laboratorio de las señales.

Basado en el registrador digital de sonido Microtrack II (M-Audio) conectado a un hidrófono SQ26-8 y controlados por una tarjeta de circuito impreso, SALu fue diseñado para producir datos de bioacústica submarina en la forma de archivos de sonido digital de hasta 24 bits de resolución y 96 kHz de frecuencia de muestreo, y desde <0,020 hasta 50 kHz, durante un periodo que, dependiendo de la configuración del modo de registro, puede alcanzar entre 14 y 86 días y noches, sin la presencia del investigador ni de su embarcación cerca del sensor. Eliminando las reacciones conductuales de los animales a la presencia de la embarcación y los ruidos que suelen transferirse al sensor debido a la actividad en la superficie, SALu es presentado como un complemento válido para las técnicas de registro acústico submarino tradicional, aportando un nuevo enfoque y registrando datos incluso cuando los puertos puedan estar cerrados por mal tiempo o en zonas remotas. SALu es recomendado para apoyar estudios oportunistas y sistemáticos, en conducta y ecología, como también, apoyar investigaciones sobre interacciones de cetáceos con actividades humanas de pesca y acuicultura. Con simples modificaciones, SALu también, puede apoyar estudios de bioacústica en tierra en campos de la herpetología, mastozoología y ornitología entre otros posibles campos.

Palabras clave: Bioacústica, Registrador Remoto, Hidroacústica, señal de sonido, vocalizaciones de cetáceos.

INTRODUCTION

Zoological studies based on the analysis of animal produced sounds are not new. However, difficulties increase when needing acoustic data from marine species. Since the contributions made by Payne and McVay (1971) on humpback whales songs, several methods to record underwater sound have been developed. The most commonly used method continuous to be the deployment, from vessels, of hydrophones connected to digital recorders. This technique is suitable for collecting hydroacoustic data from remote areas, the purpose of this contribution, but with important limitations associated with the need and presence of a vessel during the recordings. An alternative for long term studies is to use hydrophones installed on moored buoys that transmit the signal by radio to a coastal station where the recording is made. This is a method that can provide information without the presence of vessels, but it is limited to the shore, needs access to land, can be costly and the quality of the sound files can be compromised by restrictions of the analogue transmission from the buoys. Another alternative was introduced by Johnson and Tyack (2003), the DTAGs (non-invasive, digital, acoustic recording tags) consisting of self-contained devices that are attached to target individuals by suction cups. This method provides a diverse source of information and is suitable for remote areas. However, it requires a vessel for the installation of the DTAGs, as well as to follow the animals in order to recover the devices once detached. Due to size and hydrodynamic restrictions, the devices contain an amount of energy that limits their operation time to hours and potentially a few days, always with the presence of a vessel during the recordings. With the specific goal of acquiring marine mammals hydroacoustic data without human presence in the form of vessels, from remote areas accessible each two weeks at most and for short and long term studies, this contribution presents a new remote underwater bioacoustic device with long up-running time and excellent recording quality.

Acoustic efforts in Chile have been limited mainly to large whales including blue whales (Cummings and Thompson 1971; Ljungblad and Clark 1998; Ljungblad *et al.* 1998) and recently sperm whales (Rendell and Whitehead 2005). We are aware of other efforts during international and occasional cetacean surveys but we did not find publications of their analysis. Local management and scientific authorities do not have additional information. Support from Dr. Mark McDonald, starting in 1999, allowed me to develop the first local studies on small cetaceans using systematic and opportunistic passive hydroacoustics, resulting in vocal repertoire assessments of the bottlenose dolphin, *Tursiops truncatus*, and false killer whale, *Pseudorca crassidens* (Canepa *et al.* 2006; Sanino and Fowle 2006). Since then, new efforts using hydroacoustics to study free ranging cetacean

populations have joined, including blue whale (Buchan *et al.* 2010), Chilean dolphin and Peale's dolphin (Rojas 2009).

Despite that a single recording event may be far from sufficient to assess signal repertoire due to the differential vocal use related to behavioral activities (Sanino and Fowle 2006), the vocal properties can provide a valuable tool when characterizing stocks, populations or even individuals, in some cases at a faster speed than classic video/photographic tools based on visual characters. Also, data can be collected during the night or when the individuals are not able to be seen. Compared to molecular analysis, for the purposes described, the passive hydroacoustic approach can also bring results faster, at a lower cost and without the need of obtaining skin samples from individuals.

My studies using hydroacoustics have focused on two distinct geographic areas. Since 1999, studies in the area of coastal islands between the Atacama and Coquimbo regions (28.5°S; 29.5°S), focused on bottlenose dolphins, *T. truncatus*, fin whale, *Balaenoptera physalus*, blue whale, *Balaenoptera musculus brevicauda*, humpback whale, *Megaptera novaeangliae* and dusky dolphin, *Lagenorhynchus obscurus*. Since 2006, a large geographic area has been included in systematic surveys almost every week between November and April, aboard the M/V Atmosphere due to the support from *Nomads of the Seas*, a high-end tourism company. This area includes the continental coast and islands between Puerto Montt and Raúl Marín Balmaceda in Chilean Patagonia (41.5°S; 44°S). Long term acoustic efforts here have focused on Peales' dolphin, *L. australis*, Chilean dolphin, *C. eutropia*, blue whale, *B. musculus* and humpback whale, *M. novaeangliae*. The sympatric species among the two sites have been studied comparatively. These experiences may be diverse enough in both target species and environment to review some general limitations of the technique. Despite the extreme difference in the landscape at the two sites, common problems in developing systematic and opportunistic hydroacoustic studies of cetacean populations can be identified.

The technique used to collect data seems to be the source of the problem. The sound recordings are done by deploying from boats, one or more hydrophones connected to a broadband digital recorder. Most of the time, the boat has to approach close to the target individuals in order to collect signals from small cetacean vocalizations and echolocation at an intensity that can overcome the masking effect of background noise, mostly created by crustaceans. Only vocalizations from large whales or lower than 400 Hz were not subject to such difficulties and can be recorded from greater distances. However, for the rest, the presence of the boat itself can significantly affect the behavior of the animals. The noise of the engine can produce agonistic behaviors, as well as the lower pressure area created under the bow and at the stern can produce attractive behaviors. Therefore, the recorded sound signals do not necessarily reflect the repertoires that would be used if the boat were not there. The hydrophones have to be deployed while the boat is drifting, since the smallest movement would transfer water friction noise or even saturate the sensor. This limits the sites where good recordings can be achieved since wind can push the boat and drag the hydrophone. An anchor can be used but that limits the sites to those with shallow depth. I have used storm anchors (*ca.* drift anchors) in deeper waters but they take a long time to be set by which time the cetaceans often are gone. In the same way, every vertical movement of the boat (*e.g.* due to waves) can impact the hydrophone by adding noise and saturation. Also, as often is the case, the sites where we would like to record underwater sound are located in remote areas and/or experience severe weather, limiting the time the researcher can physically stay at the site per recording event.

The obvious solution would be to set the hydrophone not from boats but from the shore or with a device that can be placed on the sea floor and that can record autonomously for some time. This would not replace the boat deployed sets but add a complementary technique independent of the sea surface state, wind and without the presence of the scientists or during the night, adding a different approach.

In recent years, this has been the approach sought by the producers of hydroacoustic technology. In 2000, Joseph Olson from Cetacean Research Technology and Rodney Rountree of the University of Massachusetts at Amherst, developed the idea resulting in the first conceptual RUDAR™ prototype in early January 2002 for The National Oceanic and Atmospheric Administration (NOAA) and the University of Hawaii's Coral Reef Ecosystem Investigation. The RUDAR (Remote Underwater Digital Acoustic Recorder) is composed of a hydrophone installed in the extreme of a one meter long cylinder, also containing a ST400 Linux embedded sound recorder computer and batteries. The RUDAR has flexible programmable schemes and its manufacturer stated can work at 3500 meters depth (Cetacean Research Technology's website 2008).

The design of an underwater buoy or autonomous recording device has not been limited by the sensor (already available commercially) but the recorder itself. To control sound recorder functions remotely, without the human presence to operate them, there are two main designing concepts: a) a fully embedded computer that operates sound hardware connected to its *mainboard* as well as a storage device, just as a personal computer does but on a smaller scale, or b) a microcontroller that incorporates most of the central processing unit functions of a computer onto a small microchip. This externally controls a small sound recorder that has to be slightly modified.

The first concept option has the advantage of having the same capabilities as a personal computer in that the software that controls the recording process can be more complex. Also, the size of the memory can be large because several additional storage devices can be added. This is a similar concept to that used by the surveillance industry that adds video and sound to simplified embedded Linux computers that are able to run for a limited time on a backup battery, in case of an interruption in power supply. A popular remote recorder is the ST400 produced by Sound Technology Inc (included in the RUDAR). The computer includes an event trigger recording scheme among other interesting features. The ST400 alone has an average of one ampere of power consumption with an input of 12 VDC (Sound Technology's website). This is low consumption for a computer but a 12 VDC / 100 Ah battery would only be able to power it, with a hydrophone attached, for less than four days; even less if more storage devices are added. To increase its operating time, a greater power supply would be needed and, therefore, the device itself would grow in size.

Several companies, originally focusing on the music industry, began making small devices capable of producing sound files of high quality in flash memory media. But popular portable recorders (*e.g.*, Edirol, Marantz, Tascam) may be difficult to place in small underwater housings and/or consume a significant amount of energy. Projects for building remote autonomous underwater sound recorders were boosted by a significant change in technology allowing the production of ultra portable devices as M-Audio's Microtrack II (MKII). The device uses a small lithium battery (1200 mAh / 3.7 VCD), to record for several hours onto a CompactFlash memory card, producing very high quality sound files (24 bits / 96 kHz). Compared to the ST400 recorder, the MKII has limited results under 20 Hz, but its sample rate doubles the capabilities of the ST400 that ranges between 4 kHz and 48 kHz (Sound Technology's website).

Several projects, including my own, started to design underwater devices based on modifications of the MKII. Not only does it have low energy needs and *phantom* power capabilities but the design has few buttons to operate, reducing the complexity of an external controller. In summary, the basic idea is to connect a hydrophone to the recorder, add extra batteries and pack all inside a waterproof case. Since the scientist would not be there to press the buttons of the recorder, a custom printed circuit board (PCB) is needed to operate them. This PCB is the core for device control due to availability of cheap and programmable microcontrollers in the market; most are able to be connected through a USB cable to be programmed by a personal computer. The software to store inside the microcontroller, known as *firmware*, is the fingerprint that finally characterizes each project as it defines the behavior of the device.

Likely the first project achieving a functional prototype based on the MKII and a PCB with a microcontroller model, was the Italian RASP (registratore acustico subacqueo programmabile) (Nauta's website 2008), while others are promising their own design releases in the coming months (*e.g.*, Wildlife Acoustics Inc.). Most projects that I am aware of share the common design of a cylindrical waterproof housing made of aluminum or PCV with an acrylic custom top lid for the sensor produced by the Sexton Company. The hydrophone model SQ26-8 produced by Sensor Technology Limited in Canada is often used because it has a relatively low cost, broadband, with good sensitivity and does not need *phantom* power that would increase energy demands.

This contribution presents the results of my project for building a Seafloor Acoustic Logger unit (SALu) with specific needs that may be shared by other colleagues and were not fully addressed by other contemporaneous projects.

OBJECTIVES

The goals in designing and building a remote autonomous underwater sound recorder device were the main reasons to engage in this project. Among which I can cite: 1) when I began, there was no alternative to the RUDAR but its selling price, over 18,000 USD (*pers. comm.*, Joseph Olson), and its size were too large for my needs. The price of RASP itself was an estimated 7,000 USD while the cost of buying only the controller PCB was an estimated 500 USD (Nauta's website). The price was already an important limit at least for my budget and considering that the device might be stolen while left on the seabed; 2) most microcontroller driven devices offer a flexible programmable capability including a range of recording modes as continuous, in periods and scheduled timers, but generally time based limited. In my experience, the ratio between the recorded time in the field and the work to analyze it properly in the lab is about 1:7. Therefore, during the analysis I wanted to primarily work with true data and not environment sound (*e.g.*, waves and shrimp). I wanted a device that records not only time-based but also would have some ability to conduct real-time analysis of the incoming sound and only record sound that meet specific criteria. Sophisticated analysis would demand bigger processors, and therefore more energy and space so, this would have to be something simple but effective; 3) in order to increase the power source, more batteries can always be added but the idea was to keep the device small enough to allow one person to operate it. Also, the sensors are delicate, even to temperature changes. Therefore, I wanted the device to be safe and small enough to

be transported as a carry-on bag even on air flights; 4) RASP and its similar devices using microcontrollers instead of full computers inside, were smaller but with just few hours or days of effective work. The device, to be useful for my needs, had to be able to work autonomously for at least one week; 5) the waterproof case had to be simple in materials. In the field, in remote areas, the device must be able to be repaired with common tools, if any; 6) most devices, if not all of them, had a locked firmware/software concept. The user can define the settings for the software that will control the recorder, within a limited array of choices, but cannot access and modify the firmware itself to expand or modify the diversity of choices that defines the possible behaviors of the device. I needed a device with complete access to the software in source format in order to modify it to fit my needs (*e.g.*, adding more timers than offered); 7) the design of the cases were all as a cylinder that eases the production of the device but I wanted a shape that allows the device to be left on the seabed in the middle of a storm without extra efforts to keep it in place and with the hydrophone in the right vertical position to fully use its omnidirectional feature; 8) I never liked the idea of having the sensor protected inside a net of thick wires or hard structure that may contribute with additional surface for fouling to grow and end by covering in few days the sensor (*e.g.*, algae), a debris can get entangled inside or just the area under the protective structure over the sensor may be used by some crustaceans as their new home. Recognizing the need for sensor protection, mainly during the transport of the device, I wanted an alternative solution; 9) some of the devices in order to reduce the demand of power and stay small, sacrificed the capability to save the sound files with date and time information. A feature I consider essential if the device was expected to decide whether to record or not, based on signal properties rather than only preset timers; and finally 10) most devices offered a software to set the recording options. However, this was limited to fill variables like date, time and duration, but without feedback about the consequences of those settings considering the available power and memory of the device. Each setting demanded complex calculus by the operator if having access to the technical information of the device, just to check if there was enough energy or memory for that setting. I wanted a programmable device by a software that graphically shows the operator a good approximation of the available energy and memory in order to maximize their use

DESIGN AND CONSTRUCTION

Waterproof case

Instead of a cylinder, the case for SALu was designed as a box with two *stories* and a frontal removable lid secured in place by nine screws sealed with a conic O-rings. In the lower level are battery packs, their weight used as a ballast to bring stability. The electronics are allocated to the upper floor, contained in a retractile rack containing both the modified recorder and the *control unit* (CU) (See Figure 1).

I considered stainless steel as the primary material for the case, but for the prototype I used steel, that was hot-deep galvanized, and stainless steel bolts and screws on the main lid. Since the upper level was smaller than the base, the sensor was located in the empty space, where two bars provide additional protection during transport. The sensor is mounted in a device based on the system used by sailboats to lift and hold their mast in place. This way, the sensor is folded for its protection but once in the field, when SALu is installed, it is lifted and secured in its operative position without the needs of any tool.

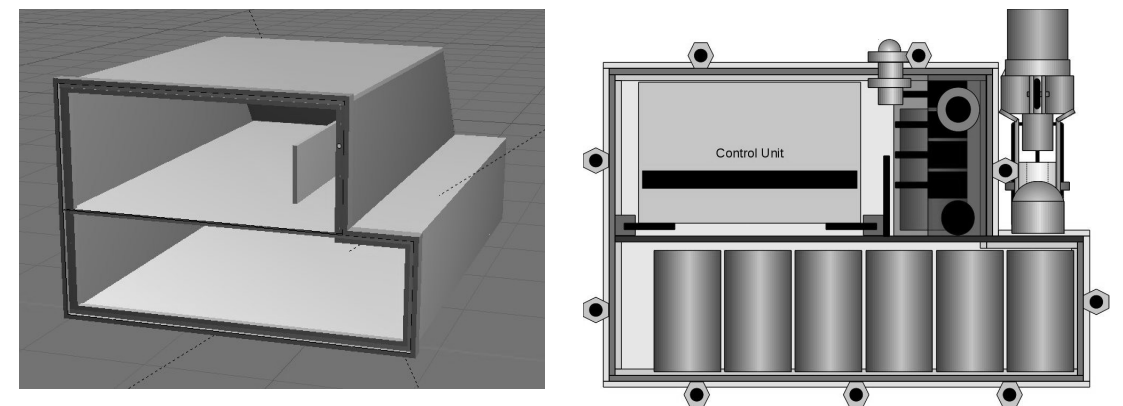

FIGURE 1. 3D model of the underwater housing (left) of the *Seafloor Acoustic Logger* unit and a frontal view of the design with the contents installed (right).

Three upper points are used to lift the unit and an additional three points in the base are used to attach *legs* that assist in adjusting the horizontal level of the unit as a tripod, to achieve the best position for the omnidirectional sensor.

Electronics

SALu includes a modified Microtrack II digital sound recorder connected to a SQ26 hydrophone. The CU contains the electronics that replace the operator in turning on and off the recorder by operating its record and play/pause buttons. The CU contains a specially designed PCB that through reed relays activates the recorder's buttons. The PCB also controls a user panel, delivers the appropriate power to the different components, provides two USB connectors and itself is controlled by a programmable Arduino Duemillanove board. Then the PCB acts as what is known as an *Arduino Shield board*, while the *firmware* developed for the Atmega microcontroller contained in the Arduino board, controls the recording behavior of SALu. The Shield and the Arduino boards are together, the CU of SALu.

To increase the potential size of the firmware, I replaced the ATmega168 microcontroller of the Arduino board, by an Atmega328 (produced by Atmel).

The Arduino based model can be used for the prototype as well as for the final design.

Considering that in the field, needs can change as well as things can go wrong, I added as a backup, a user panel in case there was a need to change the settings between the available recording modes, without having to use an external software interface. This user panel was kept simple and limited to a few light-emitting diodes (LEDs), switches and a piezoelectric buzzer. A display would not have been energy efficient and would have used ports of the Arduino board that are better used for more important tasks.

Software

Two types of software were needed to be developed. The firmware is a software of 1500 lines of code to be transferred one time to the microcontroller and then is executed every time SALu is turned on. The firmware characterizes all of the features of SALu, not only the recording schemes but also the internal clock, voltmeter, user panel, and additional features for the recovery and testing steps. The firmware was written in Java and later transferred to the microcontroller and tested with Arduino IDE.

A second software, of more than 6000 code lines, was written in Java with Netbeans 6.8 in order to assist the operator in defining and providing the values of the variables used by the firmware to set up the recording modes. This application acts as a friendly *interface* between the user and SALu, connecting to a personal computer through an USB cable, and was named SALi (Seafloor Acoustic Logger interface). Eventually, the normal user only operates SALu with SALi or directly with the panel on the CU.

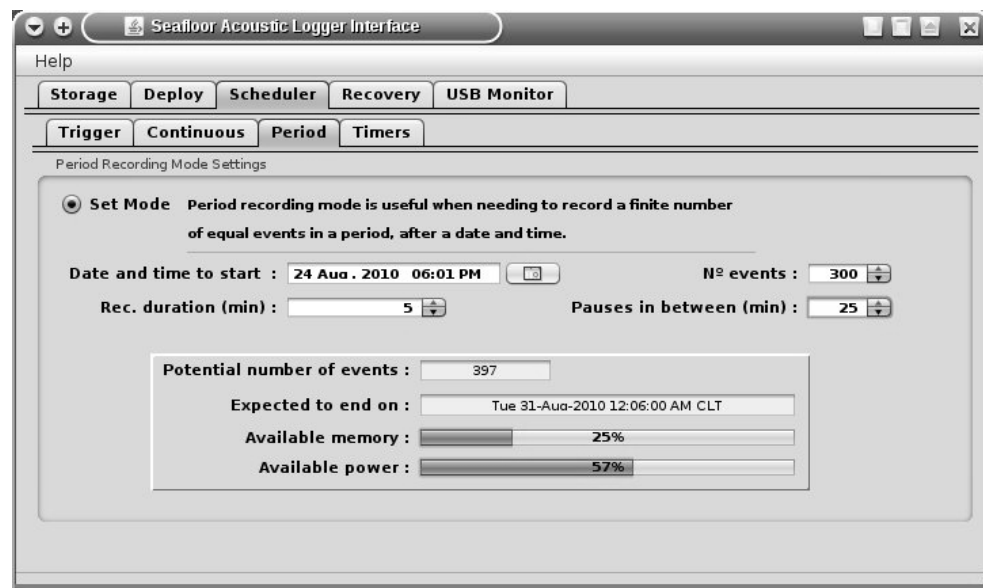

FIGURE 2. Sample of a dialog to set up the recording scheme of SALu in order to collect bioacoustic data, through the application SALi.

SALi provides dates and time in a *human* format but internally, as with SALu, does the complex calculus at millisecond precision by working in Unix time also known as Epoch format. SALi also analyzes the recording scheme settings and provides graphic feedback to the user regarding the memory storage and power availability, as well as proposing the date and time to recover SALu (See Figure 2). A high power blue LED was installed on the external surface of SALu, for the user to set with SALi, to flash a light signal during the recovery time to help relocate the unit when used in dark waters or recovered during the night. This light also flashes in a specific time after SALu is installed in order to confirm that the unit is operating properly. All applications were developed by and used on a desktop and a netbook ASUS with Linux OpenSUSE 11.2.

SPECIFICATIONS

Technical specifications of the first prototype of SALu are presented in Table 1 for future reference.

TABLE 1. Technical specifications of the Seafloor Acoustic Logger unit (SALu), an autonomous underwater sound recorder device designed to support marine wildlife hydroacoustic studies.

Section	Description
Sound Recorder	Microtrack II from M-Audio (Modified). Produces digital sound files in WAV, BWF and MP3 format, in 16 or 24 bits depth (digital resolution or number of bits of information for each sample), providing a dynamic range of 136 dB, and with sampling rates between 44.1 and 96 kHz. The recorder provides an analog filter to prevent <i>clipping</i> (distortion resulting from a signal exceeding the amplitude capabilities of the equipment), by attenuating the signals over 1 dBFS before the signal is digitalized.
Hydrophone	SQ26-08 from Sensor Technology Limited, with a frequency response between 0.020 and 50 kHz, is water resistant to 100 m of depth and is installed so that it has two positions: operative and transport. In operative position, the sensor is vertical so that the horizontal omnidirectional feature is consistent with the horizon of the environment and without any structure near the active area of the sensor.
Programming	SALu can be programmed manually using a user panel, with its own application (SALi) or by transferring a complete firmware with the defined values.
Recording modes	Four recording modes that can be selected and defined using SALi: continuously (automatically creating continuous sound files of 1.9 GB), in periods, by timers or schedulers (18 timers set by date, time and duration) or a fourth condition named <i>Trigger</i> . When SALu is set in Trigger mode, it analyzes the incoming sound in real-time taking six samples each 30 ms to be processed by a modal statistic algorithm. When the signal is higher than a threshold preset by the user with SALi, for at least 30 ms, the recorder is activated for as long as it was previously indicated. Therefore, under Trigger mode, the produced files are signal-based instead of time-based.
Recovery mode	With SALi, the user can program SALu to assist in indicating its location when recovery is in dark waters or during the night, by flashing a bright blue light and/or a buzzer at a preset time and also for a preset duration.
PC connection	An USB port used to download data and another to connect SALi with SALu to set up the recording scheme.
Dimensions	350 mm length x 235 mm wide y 149 mm height. SALu, its charger and all accessories fit in an air-flight carry-on case with wheels (<i>e.g.</i> , Pelican case type).
Weight	SALu weighs 27.5 kg including batteries.
Materials	Housing made of plates of 3 mm thick steel and hot-dip galvanized. Two zinc Mercury anodes were added for extra protection against corrosion and positioned to help protect the hydrophone. Inside retractile rack, the control unit box and the support for the recorder were made in aluminum. Through-hull wire connectors made in bronze with double O-rings.
Waterproof	The housing has been tested at depth lower than 20 meters. Further tests are needed to assess its maximum immersion capability.
Main power source	10 packs of rechargeable NiMH batteries combined to deliver 7.2 VCD / 100 A. Compared to Li-Ion batteries, they have a lower cost, do not have memory problems, keep the shape when charged and are safer despite the high amperes.
Secondary power source	Small Li-Ion battery inside the recorder (1200 mA / 3.7 VCD), only to keep the recorder's settings when SALu is off. The battery is charged during the process of downloading the files or when its USB port is connected to a personal computer or its charger. A full charge can last for several months.

Main charger	The main power source is charged with a hybrid smart charger (automatically in phases) of 3 A/h, with an autovoltage input (110-220 VAC). When connected, a temperature sensor installed between the batteries permits the charger to monitor the process for additional safety.
Charging time	The first full charge of all battery packs takes an estimated 35 hours. The next charges takes an estimated 10.2 hours.
Life cycle	The battery provider states that their product can be charged at least 1000 cycles before having to be replaced.
Recorded media	CompactFlash (CF) memory cards between 4 GB and 100 GB.
Memory use	Depending on the preset quality, the memory use varies. At best quality (24 bits / 96 kHz), 32 GB, 64 GB and 100 GB memory cards correspond respectively to 16h:34min:12s, 33h:8min:24s and 51h:47min:5s. Only under the Continuous recording mode is the memory use consistent with the total endurance of SALu. In all three other recording modes, the memory is distributed to produce data from a greater amount of time. When using the Trigger recording mode, SALu can be active for almost two weeks depending on the abundance of recorded events. If lower recording qualities are used, the amount of time that the memory can store increases dramatically (e.g., a board of 32 GB, recording at 44.1 kHz/16 bits, can store more than 101 hours).

TESTS

Use of energy

The time that SALu may stay on and record underwater sounds may vary depending on the set recording. The use of energy depends on how long of a time the recorder has to be on and recording as well as the use of the user panel features. To test the maximum endurance of the available energy, the ten battery packs of the main power source were fully charged. Immediately after charging, the batteries were warm and a digital voltmeter indicating 8.19 VCD. After 20 minutes to let the batteries cool down and stabilize their charge, the voltage lowered to 7.96 VCD. Instead of disconnecting the power source from the control unit on every voltage measure, the voltmeter was connected to the electrodes of the power source while SALu was on. Despite the read values would be lower than the absolute values, the continuity of the test was maintained.

Two types of tests were developed, one for maximum drainage of energy and another for minimum drainage, both with only one of the ten packs activated (a 10 A power source). In order to assess the maximum autonomy of SALu with the designed power source, a second firmware for testing was developed that activated all of the energy demanding features (Arduino board, seven LEDs, a piezoelectric buzzer, reed relays, all elements of the shield board, and the recorder with the hydrophone connected).

The unit was kept at temperatures lower than 10 °C, since at lower temperatures the batteries may perform less optimally than at higher temperatures. SALu was turned on and every 20 minutes the voltage was measured. SALu had all the features active for 2088 minutes (about 35 hours - 287 mAh). Therefore, with the ten battery packs activated (full power source), SALu should endure for at least 348 hours (14.5 days). This was a forced condition that SALu would not replicate under normal use, since its different elements are never active simultaneously and its firmware includes functions to save energy. Therefore, this test included a broad margin of safety.

In order to test endurance with the minimum drainage of energy, a different battery pack was activated

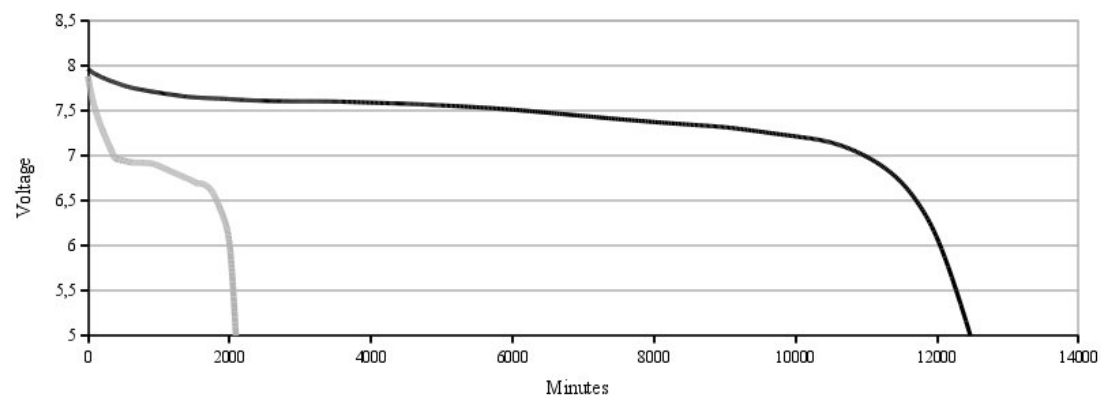

FIGURE 3. Curves of energy use, of only one of the ten battery packs, by SALu with all features activated (gray line) and with power saving mode (darker line).

of the same initial charge set. The firmware used for this test was designed to activate SALu's features as under normal use, but then to keep the control unit in the standby mode (recorder, hydrophone, user panel and sections of both the Arduino and shield boards off) representing the status of SALu when it is waiting for the next recording event. The test was conducted at room temperature (20 °C) and SALu was active and responsive (able to turn on the recorder if the instruction was indicated through a button) for 12.400 minutes. With the power source fully activated (10 packs), the endurance of SALu while in standby mode should be an estimated 86 days.

Figure 3 presents the curve of energy use for the two tests.

Transportability

SALu and all its accessories, were stored in a Seahorse case (SE-920). The case is approved as a carry-on for air-flights and has two wheels (Figure 4). Underwater tests had been done from the stern of M/V Atmosphere in Puerto Montt and in Tictoc bay during diverse time lengths and in minor depths less than 20 meters, set alone for 12 hours at 10 m depth in Edmundo islets in Patagonia then finally tested near Chañaral island at four meters depth in front of a cliff. To do this, SALu has already traveled 2.000 km in buses, 2.600 km by air, several hundreds of nautical miles by ship, and in the back of a pickup truck on 350 km of dirt and sandy roads, and 1.000 km by highways. No signs of damage of any type have been detected.

In Edmundo islets, SALu was lowered from a small inflatable boat, with a rope attached to a buoy. There are three points to attach the rope to SALu in order to keep it in balance and out-of-the-way of the hydrophone. No external floating device was needed and a single operator easily deployed SALu, despite bad weather. The buoy was submersed due to the tidal change but SALu remained in place. The process of recovery went easily as well by simply pulling the rope attached to SALu. The seabed was muddy but the shape of SALu kept it in place, no mud was found nearby the sensor.

Near Chañaral island, the seabed is rock in a kelp forest with moderate currents. SALu was deployed again, from an inflatable boat, and a diver transported it with the help of an air lift bag. The recovery was done by a diver that attached a rope to SALu and then lifted it to the small boat.

The number and position of the batteries, provided a good balance between lightness, to transport it by hand, manipulate it in small boats and dive with it, and heaviness to stay in place by itself in the seabed.

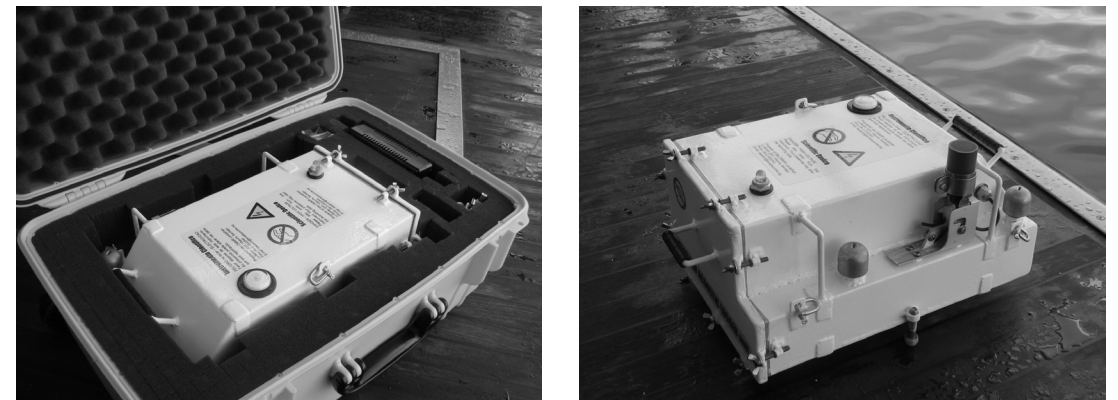

FIGURE 4. Seafloor Acoustic Logger unit (SALu) and its accessories transported in a waterproof case (left) and SALu, ready to be deployed from the stern of M/V Atmosphere (right).

Weather independence

SALu was deployed from a small boat, on 30 January 2010 at 7:30 pm for an estimated 12 hours in Edmundo islets (47°59.17'S; 73°38.94'W). It was impossible to deploy a hydrophone from the surface at the same time, due to difficult weather conditions (>6 in Beaufort scale).

The produced sound signal is clear enough to recognize rain and wind gusts on the surface. Despite a sample of the spectrography and *spectrum* of the data collected is presented in the next figure.

If we were limited to the technique of using hydrophones from boats, we would have not been able to obtain useful hydroacoustic data. The movements of the boat would have dragged the sensor saturating the signal and the boat itself would have had to keep the engine on, considering the close distance to the shore. This would have added significant noise.

At the testing near Chañaral island, 3 August 2010, a similar recorder and also hydrophone were used

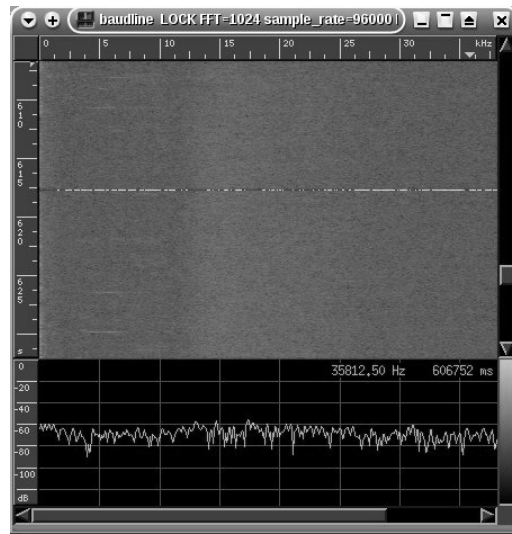

FIGURE 5. Spectrography (upper area) and spectrum (lower area) signal of a sample of sound data produced by SALu, in Edmundo islets, Aysén region (Patagonia - Chile), during a storm. The spectrography has time in the vertical axis and frequency in the horizontal axis.

also from the boat in order to compare the quality of the sound produced by SALu. Another storm, even in the inflatable boat, made not safe to approach to the exact site of SALu (29°1.41'S; 71°34'W). Therefore, the boat had to deploy its hydrophone from the surface at some distance from the island. The main disadvantage of this, was that the distance would decrease the main background noise produced by crustaceans in the shore, compared to SALu positioned directly over the rocks.

The following figure compares spectrograms from recording events from both the boat and the seabed.

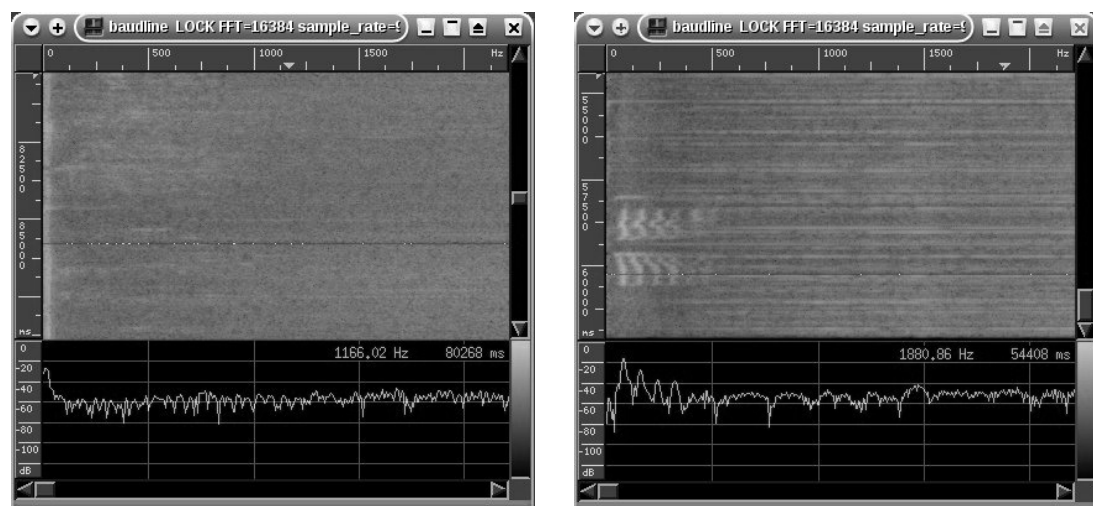

FIGURE 6. Spectrographies (upper sections) and spectra (lower sections) of a sound samples taken: with a Microtrack II recorder connected to a SQ26-8 hydrophone deployed from a boat at 300 m from the shore (left), and by SALu at four meters depth directly in the shore (right).

Figure 6 shows in the spectrography from the boat, noises below 1.000 Hz, created by water splashing against the hull due to waves and wind. This noise is absent in the spectrography made by SALu, despite that the level of background noise from crustaceans was higher. In general terms, the quality is similar by both techniques except when analyzing at very low frequencies (left vertical axis in the spectrographies). Data produced from the surface presents a high level of constant noise below 50 Hz, something that does not appear to be the case with SALu despite the fact that the hydrophone and recorder were, in both cases, the same and the engine of the boat was off while recording.

Stability

During the study in Patagonia that included Edmundo islets, in several cases we had problems with the electronic equipment due to harsh conditions. Neither the GPS (Loox T830 with Sirf III chip) nor the sound recorder worked unless they were kept warm inside our vests or inboard. The area is between several glaciers and there was particularly bad weather at the time (Sanino y Yáñez 2010). In order to check the stability of SALu's microprocessors, it was programmed on Continuous mode. If any interruption razed to the microprocessors, the recorder would stop working or the produced sound files would result unevenly distributed in time. The records made by SALu were uninterrupted and consistent with the programmed recording scheme. Not only was the microprocessor stable in harsh conditions but also the recorder. The conditions underwater may have been less harsh than at the surface. Also, several electronic elements as resistors and microprocessors liberate some heat that may have contributed as well.

During the tests while hanging from the stern of M/V Atmosphere (at 3, 5, 8, 10, 15, 20 meters depth), as well as the entire time SALu was left in Chañaral island, no evidence of electronic nor processing instability was found in any of its recording modes.

Biosounds

During the tests, SALu produced sound files with data containing signals attributed to a biologic origin, including shrimp and whales (see Figure 6, to be discussed in another contribution) despite the storm and hard conditions. *Trigger* recording mode has not yet been tested in an autonomous test in the field. In lab conditions, SALu has performed in *Trigger* mode as expected. However, additional tests are needed to calibrate the threshold to collect the target biosounds. It has been tested for human voice and while reproducing previously recorded cetacean vocalizations, resulting different sets of thresholds.

Before setting SALu in *Trigger* mode in the field, a more complete review with prerecorded vocalizations is in process in order to produce a table with the ranges of threshold for the different types of target signals. Functional results of *Trigger* mode depend on the target signal characteristics and the threshold set with SALu. While located on the seafloor, *masking* was a major potential problem for SALu, due the crustacean sound production. However, and despite that crustaceans were recorded at high levels their signals were not able to mask other biosound. Crustaceans *clicks* are potentially high enough to trigger recording events of SALu when set on *Trigger* mode. However, in reproduced conditions, SALu was not triggered by crustaceans because the algorithm needs peaks for at least 30ms long.

CONCLUSIONS

Initial tests of the Seafloor Acoustic Logger unit (SALu), show promising results. As a device able to record underwater sound from the seabed for an estimated two weeks, SALu is presented by this contribution as a complementary technique to the traditional method of producing acoustic data by deploying hydrophones from boats.

Away from the variables affecting the surface of the sea, the sensor is located in a waterproof case with a recorder controlled by a microcontroller that has a software with the instructions previously defined with an application installed on an external personal computer. The design followed a series of requests razed from reviewing the general limitations of the traditional techniques and the common concepts of general alternative designs of remote autonomous underwater sound recorders.

The sound files produced by SALu showed an improvement, compared to records from the same model wired hydrophone at the surface, in lower frequencies.

The design of the case resulted stable to be deployed directly on the seabed without extra procedures and light enough to be handled by a single operator in small boats with or without diving (Figure 7). The electronic components showed to be reliable staying stable even under hard conditions, producing high quality sound files on sites where was not possible from the surface.

Abundant crustacean sound production did not present masking effects during field tests nor did it trigger recording events by SALu under *Trigger* mode in lab tests.

Due to the characteristics found near Chañaral island, Sanino and Fowle (2006) highlighted the need to install a fixed hydrophone network, based in recording stations without the presence of boats, to develop long-term acoustic studies in the area. A series of devices like SALu may be appropriate for these stations since SALu produces sound data passively and without needing a boat as a platform that always produces noise with the potential of inducing behavioral modifications. The batteries would have to be recharged and data downloaded every two weeks depending on the recording scheme. Sound data would be produced even when the local port is closed for small boats due to inclement weather. Similar stations can be developed in Choros island, at only 27 km South, which would contribute towards the completion of the vocal repertoire of pod-R (the local resident pod of bottlenose dolphins, *Tursiops truncatus*), (Sanino and Canepa 2005; Canepa *et al.* 2006) and develop studies on its dynamics. The coastal island close to the border between the Atacama and Coquimbo regions of Chile also seems to be the appropriate site to develop cetacean bioacoustic studies considering the presence of a high diversity of large and small cetacean species (González *et al.* 1989; Yáñez 1997; Findlay *et al.* 1998; Capella *et al.* 1999; Van Waerebeek *et al.* 1999; 2006; Sanino and Yáñez 2000; 2001a; 2001b; Sanino and Canepa 2005; Sanino and Fowle 2006; Sanino and Van Waerebeek 2008; Sanino *et al.* 1996; 2003a; 2003b; 2005, 2007).

SALu followed the option of the microcontroller concept, achieving a consumption at least four times lower than computer embedded options such as the ST400, doubling the quality of the sound files (96 kHz of sample rate) and maintaining a small physical size. A microcontroller concept has limited options compared to a full computer but SALu mitigates this difference by having full access to the firmware of the microprocessor. If there is a specific recording scheme needed that is not covered by the proposed recording modes, the firmware can be modified to include it. A limitation may be the storage size, which is actually up to 100 GB. However, the CompactFlash memory card is popular media that is expected to continue its development (CompactFlash Association's website).

Underwater environmental conditions may represent a more complex scenario than inland bioacoustic studies. Without pressure and extreme corrosion problems, SALu can be installed in alternative fiberglass cases to resemble a stone or a branch on a tree where the hydrophone may be replaced by normal microphones to collect biosound data in alternative research fields (*e.g.*, herpetology, mammalogy and ornithology).

Sanino and Fowle (2006) presented analytic methods using free software or under GNU General Public License, particularly highlighting the benefits of using Baudline as a digital processing signal when analyzing biosound data. Here, I highlight the benefits of extending this concept to the design of data logger prototypes, by using the tools offered by Arduino both as hardware and software, and software development using Netbeans, Eclipse, Kdevelop or similar tools.

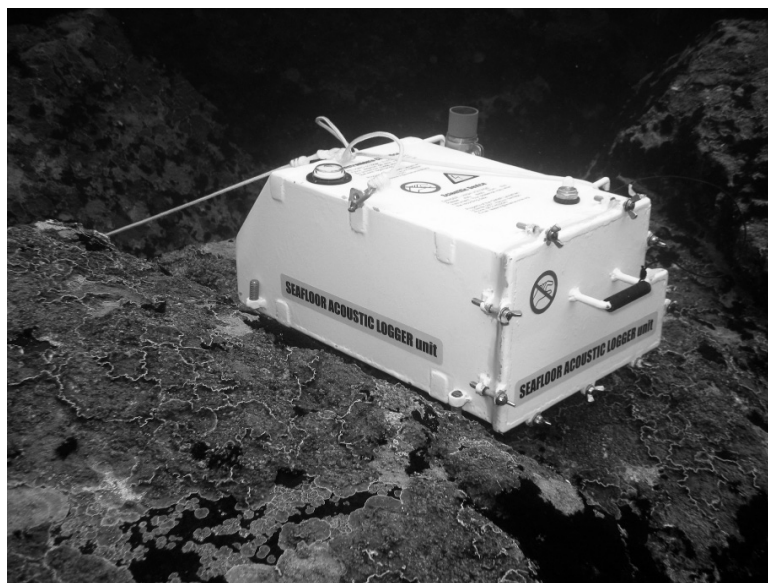

FIGURE 7. Seafloor Acoustic Logger unit (SALu) installed in the rocky seabed Northeast of Chañaral island, Atacama Region, Chile.

ACKNOWLEDGMENTS

Special thanks to OAK Foundation and Duke Centre for Marine Conservation for their trust and support for this project; to Nomads of the Seas and the M/V Atmosphere crew that allowed me to work inside common spaces while building important sections of SALu onboard; to José Yáñez for his permanent support including in the freezing areas of Tortel; and to the opensource Arduino forum / community for making important Java libraries improvements together and always responding the requests of this member.

Special thanks to Celine Cousteau for her support during the successful test in Chañaral island and to Cesar Villarroel (head of Explorasub) for his photography and diving expertise when installing SALu in Chañaral island. And last but not least, thanks to Ann Michels, for her kind review of this manuscript.

REFERENCES

- BUCHAN, S. J., L. E. RENDELL and HUCKE-GAETE, R.
2010 Preliminary recordings of blue whale (*Balaenoptera musculus*) vocalizations in the Gulf of Corcovado, northern Patagonia, Chile. *Marine Mammal Science*, 26: 451–459.
- CANEPA, A. J., G.P. SANINO, and J.L. YÁÑEZ, 2006. "Preliminary note of the vocal repertoire of a resident population of common bottlenose dolphins, *Tursiops truncatus*, in Chile". *Boletín del Museo Nacional de Historia Natural (Chile)*. 55: 41-49.
- CAPELLA, J., Y. VILINA and J. GIBBONS
1999 Observaciones de cetáceos en Isla Chañaral y nuevos registros para el área de la Reserva Nacional Pingüino de Humboldt, norte de Chile. *Estudios Oceanológicos* 18: 57-64.
- COMPACTFLASH ASSOCIATION
2010 <http://www.compactflash.org/>
- CUMMINGS, W. C. and THOMPSON, P. O.
1971 Underwater sounds from the blue whale, *Balaenoptera musculus*. *Journal of the Acoustical Society of America*. 50:1193-1198.
- FINDLAY, K., PITMAN, R., TSURUI, R., SAKAI, T., ENSOR, K., IWAKAMI, P., LJUNGBLAD, D. K., SHIMADA, H., THIELE, H., VAN WAEREBEEK, K., HUCKE, R. and SANINO, G.P.
1998 1997/1998 IWC-Southern Ocean Whale and Ecosystem Research (IWC-SOWER) Blue Whale Cruise, Chile. Final Report of the third IWC Blue Whale Cruise of the International Whaling Commission SOWER program. 39pp.
- GONZÁLEZ, J., CAPELLA, J. and GIBBONS, J.
1989 Delfines nariz de botella *Tursiops truncatus* (Montagu, 1821) habitando frente a isla Chañaral, Provincia de Huasco, Chile. *Estudios Oceanológicos*. 8: 67-71.
- JOHNSON, M. P. and TYACK, P. L.
2003 A digital acoustic recording tag for measuring the response of wild marine mammals to sound. *IEEE J. Oceanic Eng.* 28, 3–12.
- LJUNGBLAD, D. K. and CLARK, C. W.
1998 Unique calls of the pygmy blue whale recorded off the coast of Chile in Dec 1997 and Jan 1998 during the SOWER 1997/98 program. Paper SC-50-CAWS29 presented to the IWC Scientific Committee June 1998.
- LJUNGBLAD, D. K., CLARK, C. W. and SHIMADA, H.
1998 A comparison of sounds attributed to pygmy blue whales (*Balaenoptera musculus breviceauda*) recorded south of the Madagascar Plateau and those attributed to 'True' blue whales (*Balaenoptera musculus*) recorded off Antarctica. *Report of the International Whaling Commission*. 49: 439-442.
- NAUTA
2008 Strumenti e consulenza scientifica. <http://www.nauta-rs.it>
- OLSON, J. R.
2008 Cetacean Research Technology - <http://www.cetaceanresearch.com>
- PAYNE, R. and McVAY, S.
1971 Songs of humpback whales. *Science*, 173: 585–597.
- RENDELL, L. and WHITEHEAD, H.
2005 Coda playbacks to sperm whales in Chilean waters. *Marine Mammal Science*. 21(2): 307-316.
- ROJAS, R.
2009 Caracterización del repertorio acústico del Delfín chileno *Cephalorhynchus eutropia* (Gray, 1846) y del Delfín Austral *Lagenorhynchus australis* (Peale, 1848) en la Isla de Chiloé, Región de Los Lagos, Chile.

- Tesis presentada ante la Universidad Austral de Chile.
- SANINO, G. P. and YÁÑEZ, J. L.
2010 Monitoreo de mamíferos marinos, Proyecto Hidroeléctrico Aysén. Informe de línea de base V2.1, contrato CA-068-09. 128 pp.
- SANINO, G.P. and VAN WAEREBEEK, K.
2008 A note on the southern distribution range of inshore and offshore common bottlenose dolphins *Tursiops truncatus* in the Southeast Pacific. Document SC/60/SM18, presented to the Scientific Committee of the International Whaling Commission.
- SANINO, G.P., JOSÉ L. YÁÑEZ and VAN WAEREBEEK, K.
2007 A first confirmed specimen record in Chile, and sightings attributed to the lesser beaked whale *Mesoplodon peruvianus* Reyes, Mead and Van Waerebeek, 1991. Boletín del Museo Nacional de Historia Natural (Chile). 56: 89-96
- SANINO, G. P. and FOWLE, H. L.
2006 Study of whistle spatio-temporal distribution and repertoire of a school of false killer whales, *Pseudorca crassidens*, in the eastern South Pacific. Boletín del Museo Nacional de Historia Natural (Chile). 55: 21-39.
- SANINO, G. P. and CANEPA, A. J.
2005 Determinación Preliminar del Repertorio Vocal de la Población Residente de Delfines Nariz de Botella, *Tursiops truncatus* (Montagu, 1821), y su Posible Asociación a Eventos de Turismo, isla Choros (29°16'S, 71°32'O), IV Región, Chile. Presentado durante la XX Reunión de la Sociedad Argentina para el Estudio de los Mamíferos – SAREM.
- SANINO, G. P., VAN WAEREBEEK, K., VAN BRESSEN, M. F. and PASTENE, L. A.
2005 A preliminary note on population structure in eastern South Pacific common bottlenose dolphins, *Tursiops truncatus*. IWC Journal of Cetacean Research and Management. 7(1): 65-70.
- SANINO, G. P., VAN WAEREBEEK, K. and YÁÑEZ, J. L.
2003a Revisión de la distribución del género *Delphinus*, y registros documentados de *Delphinus capensis*, en Chile. Boletín del Museo Nacional de Historia Natural (Chile). 52: 97-102.
- SANINO, G. P., HAMILTON-WEST, C., ROJAS, A., YÁÑEZ, J. L. and VAN WAEREBEEK, K.
2003b Estudios de restos varados de *Delphinus delphis*, y primer registro documentado de neumonía focal abscedativa, en Chile. Boletín del Museo Nacional de Historia Natural (Chile). 52: 103-177.
- SANINO, G. P. and YÁÑEZ, J. L.
2001a Nueva técnica de video identificación y estimación de tamaño poblacional en cetáceos, aplicada en delfines nariz de botella, *Tursiops truncatus*, de isla Choros, IV Región de Chile. Boletín del Museo Nacional de Historia Natural (Chile). 50: 37-63.
- SANINO, G. P. and YÁÑEZ, J. L.
2001b Estudio de un ejemplar de *Globicephala melas* varado en la III Región y revisión de los registros del género para Chile. Boletín del Museo Nacional de Historia Natural (Chile). 50: 21-36.
- SANINO, G. P. and YÁÑEZ, J. L.
2000 Efectos del turismo de observación de cetáceos en Punta de Choros, IV Región, Chile. Revista Gestión Ambiental (Chile). 6: 41-53.
- SANINO, G.P., GALÁZ, J. L., YÁÑEZ J. and CAPELLA, J.
1996 New record of a Cuvier's beaked whale, *Ziphius cavirostris*, Cuvier 1823 in Chile and review of previous cases. Noticiario Mensual del Museo Nacional de Historia Natural (Chile). 325: 33-37.
- SOUND TECHNOLOGY INC.
2010 <http://www.soundtechnology.com>
- VAN WAEREBEEK, K., VAN BRESSEM, M. F., ALFARO-SHIGUETO, J., SANINO, G. P., MONTES, D. and ONTON, K.
1999 A preliminary analysis of recent captures of small cetaceans in Peru and Chile. Paper SC/51/SM17, Scientific Committee IWC, Grenada, May 1999.
- VAN WAEREBEEK, K., BAKER, A. N., FÉLIX, F., IÑIGUEZ, M., SANINO, G. P., SECCHI, E., SLOCUM, G., SUTARIA, D., VAN HELDEN, A., and WANG, Y.
2006 Vessel collisions with small cetaceans worldwide and with large whales in the Southern Hemisphere, building a standardized database. SC/58/BC6, presented to the 58th Meeting of IWC, St Kitts, May-June 2006.
- WILDLIFE ACOUSTICS INC.
2010 http://www.wildlifeacoustics.com/sm2_water.php

YÁÑEZ, J. L.

- 1997 Reunión de trabajo de especialistas en mamíferos acuáticos para categorización de especies según estado de conservación. Noticiario Mensual del Museo Nacional de Historia Natural Chile 330:8-16.